

WAYLAND FREE PUBLIC LIBRARY

3D Design and Printing Tutorial: Create a Keychain

Welcome! In this tutorial we will be creating a 3D printed keychain. You will personalize this name tag with text to make it unique, then 3D print it so you can bring it home. Towards the end we will also go over some more advanced, but extremely useful, tools and techniques. Let's get started!

Pg. 2: Getting started

Pg. 3: Moving around in Tinkercad

Pg. 4: Resizing and rotating shapes

Pg. 5: Creating the keychain shape

Pg. 6: Creating the indent in your keychain

Pg. 7: Adding the text and keyring to your keychain

Pg. 8 and beyond: Other tools and techniques

This is Tinkercad

1. The picture below is an empty Tinkercad workspace.
2. The right side menu is where the shapes/objects will be.
3. A Tinkercad.com account is totally free, all you need is an email address and you don't even need to download anything.
4. *If you are doing this from home, it is strongly recommended that you use a mouse/keyboard setup.*

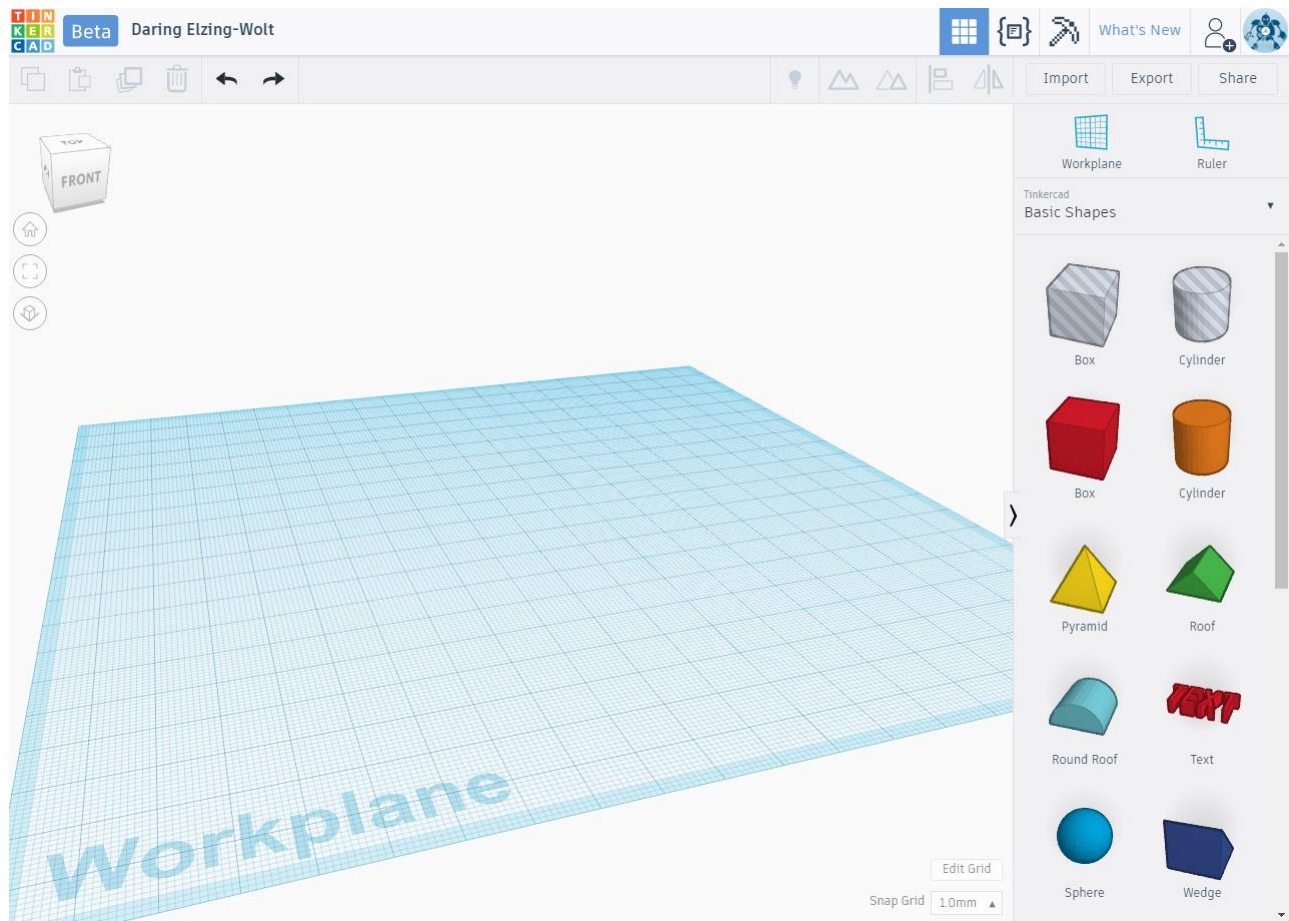

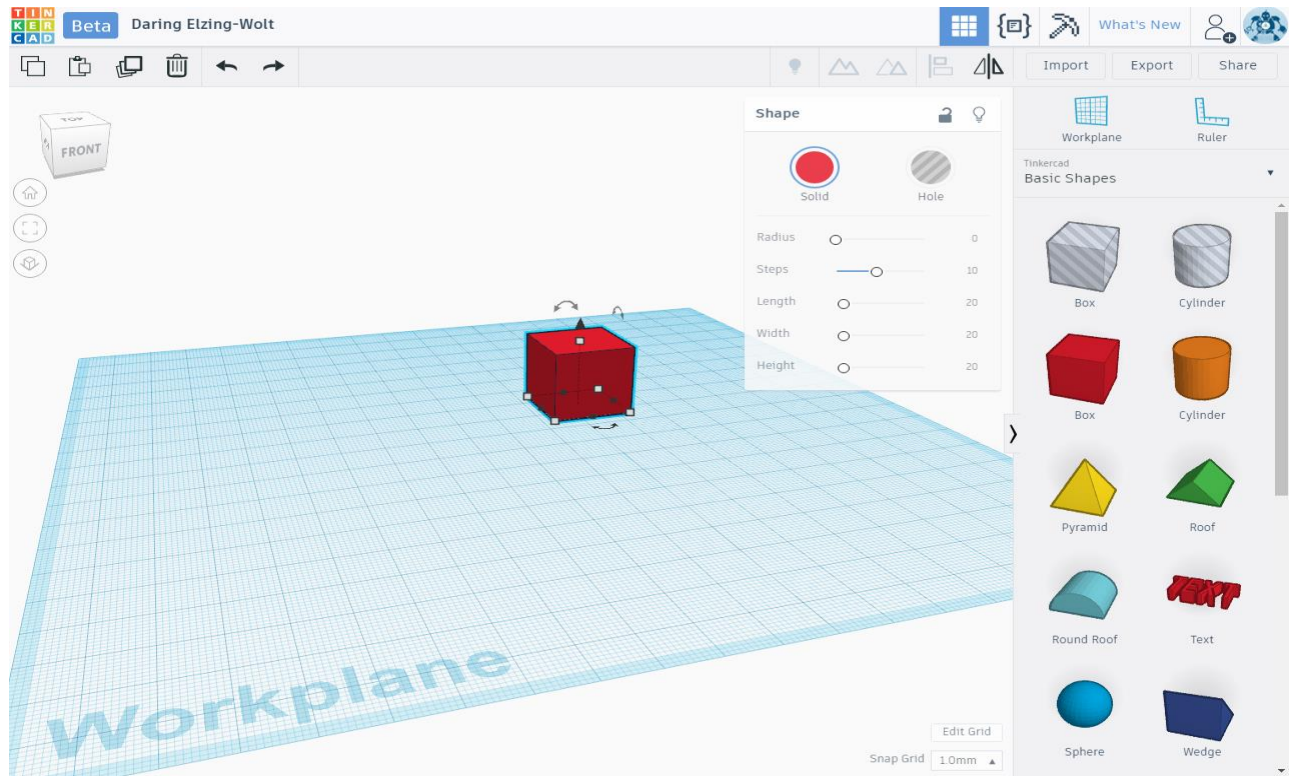

Moving around TinkerCad

1. Drag a square into the scene from the Tool Bar panel on the right.
2. **Turn** by right clicking and moving the mouse.
3. **Zoom** by scrolling your mouse wheel.
4. **Move** or **pan** by right clicking your mouse and holding shift or by clicking and dragging the middle mouse button.
5. Reset your view by clicking on the **Home** icon in the top-left corner of the screen.
6. You can **move objects around** by holding down left on an object and moving your mouse. You can also select it with left click (don't need to hold it down) and use the arrows keys on your keyboard.
7. **Made a mistake/don't like how a change looks?** Simply hit 'ctrl+z' (or 'command+z' on Mac) on your keyboard to undo any changes. You can go back as many steps as you need to.
8. Before deleting your square, note the small menu that popped up when you first dragged it out. The sliders can be used to easily manipulate your shape beyond simply resizing/rotating it.

Resizing and rotating shapes

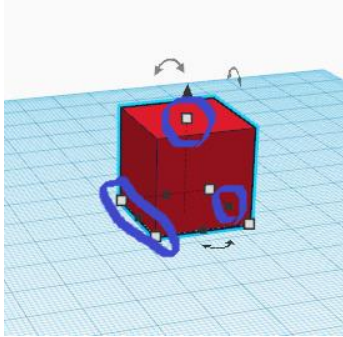

1. The simplest way to resize shapes is by holding down left click on one of the small black or white squares.
2. Then, move your mouse around to push/pull the object into different dimensions. To get a better idea, see the pictures below.

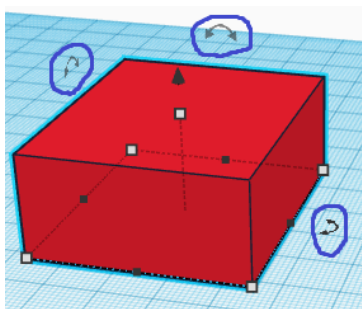
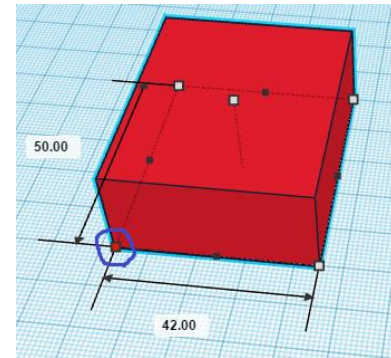
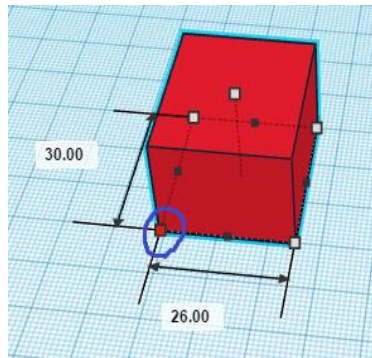

1. To rotate objects, hold down left click on one of the double sided arrows and move you mouse.
2. You will notice when you click that it brings up a radial or circle around the object. To rotate in even increments (bottom left, at 45), keep your cursor inside that circle. To rotate to a specific or singular degree (bottom right, at 49), keep your cursor outside the circle.

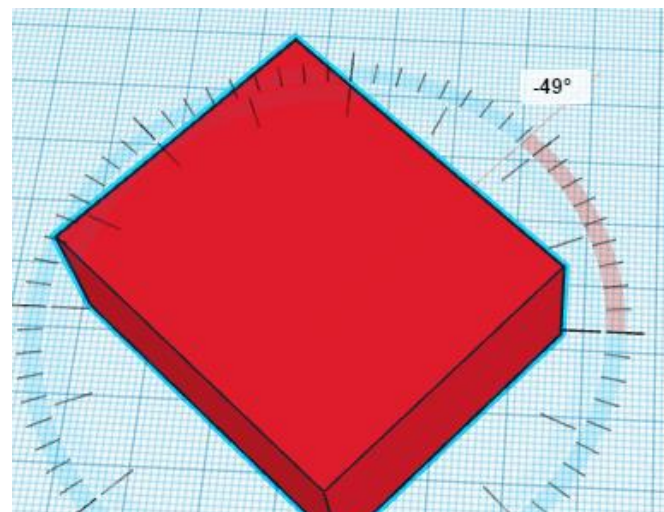
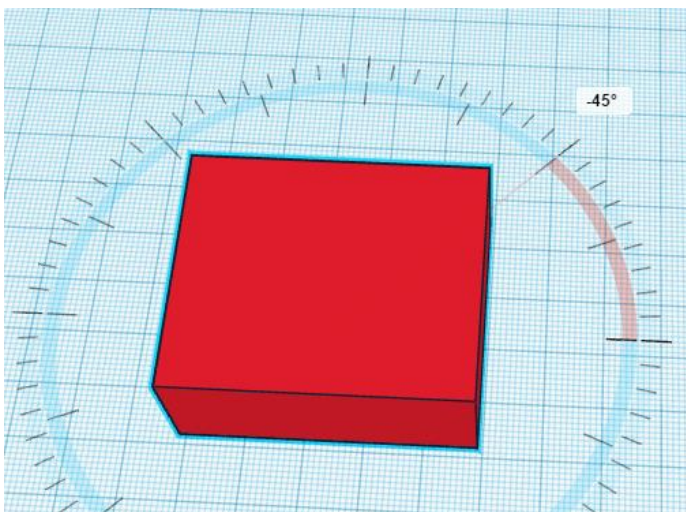

Create the keychain shape

1. Restore the default view by clicking the 'home' button (left menu). Start by dragging a square or 'box' onto the workplane.
2. Select one of the small black squares on the right or left, and pull out the cube until the measurement is anything between 60-70mm. Remember to hold left click.

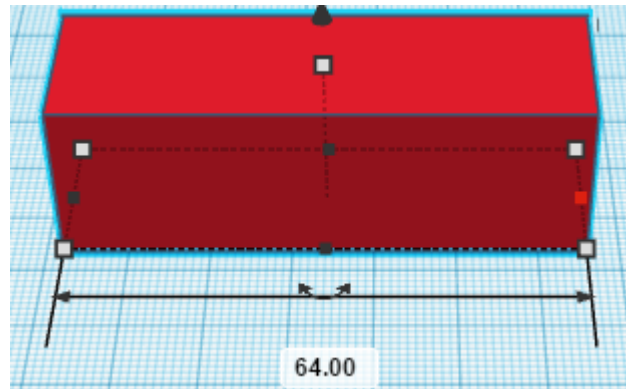

3. Just like step 2, select one of the small black squares on the top or bottom, and pull out the cube until the measurement is anything between 25-30mm.
 4. Now, grab the small white square at the top, and push the shape down until the measurement is between 8-10mm.
5. Your shape should look something like this:

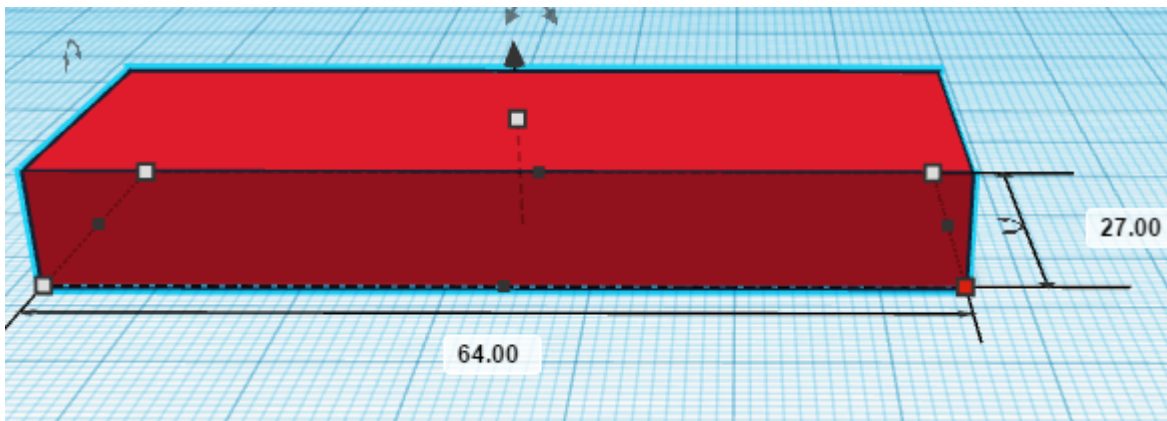

Create the rim or indent on your keychain

1. Hit 'w' on your keyboard. This will bring up a small white plane that you can move around with your mouse. Move it so that it is resting on top of your keychain shape.

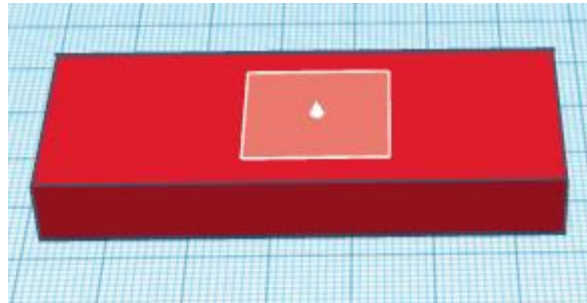

2. And 'left click'. Now, any new objects you drag out will be placed directly on top of your keychain.
3. Drag out another cube or box. Try to position it in the middle of your keychain shape, and then use the left/right black squares to pull out the sides. It should look like:

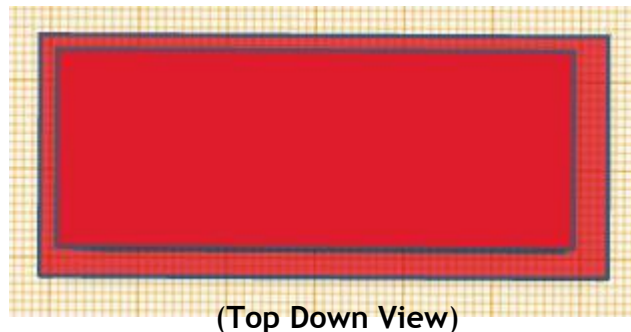

4. Select the object resting on top, and click on the 'hole' function.

5. Hold down 'ctrl' (or 'command' on Mac) and hit the down arrow on your keyboard 2-4 times.

6. Hold down left click outside both objects, and use your mouse to create a selection box around both of them (shown bottom left). Then click the 'group' function (shown bottom right). After clicking group, your keychain shape will now have an indent or rim.

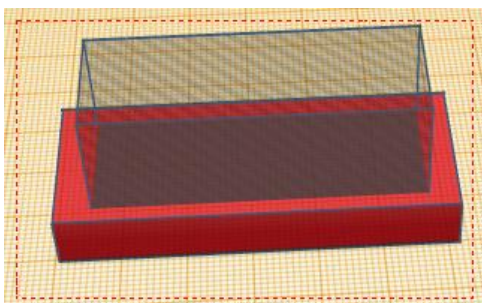
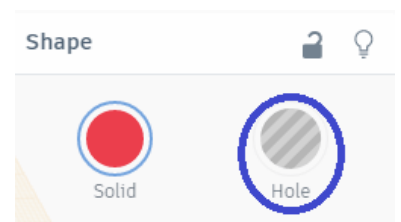

Adding text and the keyring

1. Hit 'w' on your keyboard again, and place the plane on the newly formed indent.

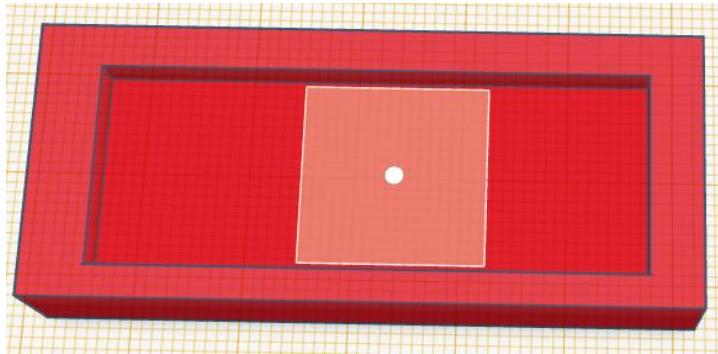

2. Drag out a 'Text' object from the right hand menu. It will be large compared to our keychain shape, so resize it (with the black/white squares) until it fits how you want it. Play around with the sliders and enter whatever text you want.

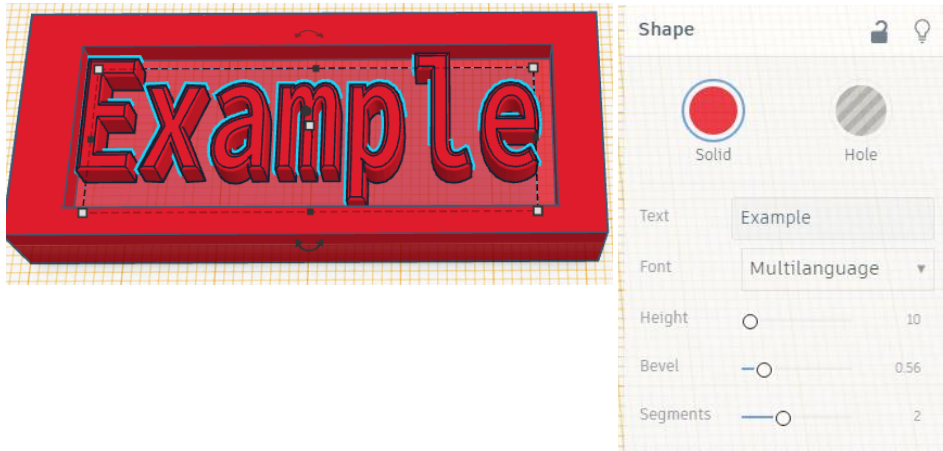

3. To add a keyring, hit 'w' again and place the plane anywhere outside of your keychain. Drag out a 'Torus' shape from the right hand menu (you will likely have to scroll down). Then, position it wherever you like on your keychain - just be sure to put some of it inside the keychain (see below picture). Then, as before, put a selection box around everything, click 'group', and your keychain is complete!

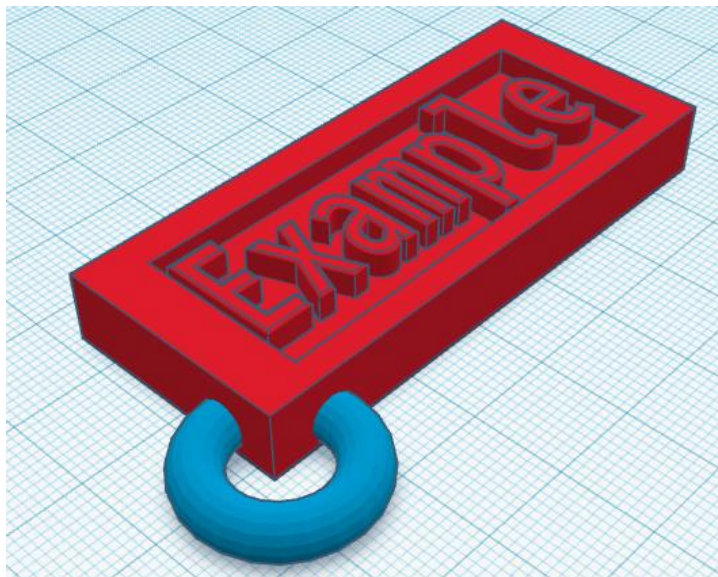

Other tools and techniques

1. The **'Ruler'**. Shown below left, you can also just hit 'R' on your keyboard. The ruler is useful for when you need to assign specific dimensions to a design. Simply click on one of the numbers and you can enter a number (18.70mm in the below example) on your keyboard.

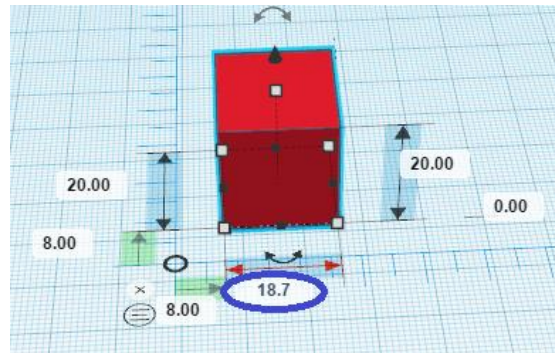
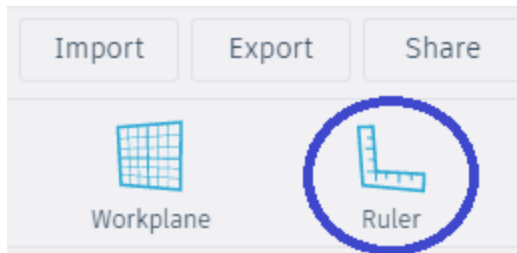

2. The **'Align'** tool. Shown below, the align tool is an easy way to line up multiple objects so that they are all centered or left/right. After selecting all relevant objects and clicking on the align tool, click the alignment (center, left, etc) needed. An example of center alignment is shown below.

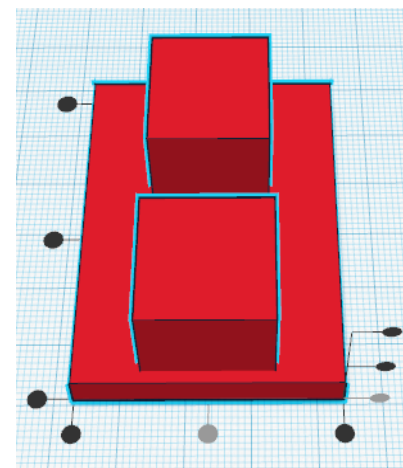
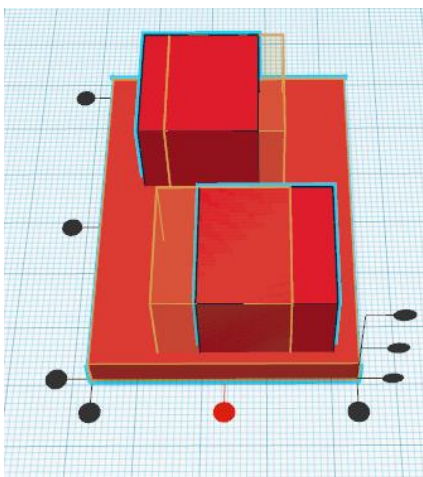

3. **Duplicate.** Shown below, or by keyboard shortcut 'ctrl + D' (also 'ctrl + D' for Mac), this tool is very useful for quickly making repeating patterns. Select an object, use duplicate (you should see a brief flash around the object), and then reposition/rotate/resize the object. Use duplicate again, and again, and you will notice the pattern repeats itself as many times as you want. In the pictures below, this tool is used to quickly create stairs and the petals of a flower. **Note:** do not click off of objects you are duplicating, this will reset the tool and erase your pattern.

